

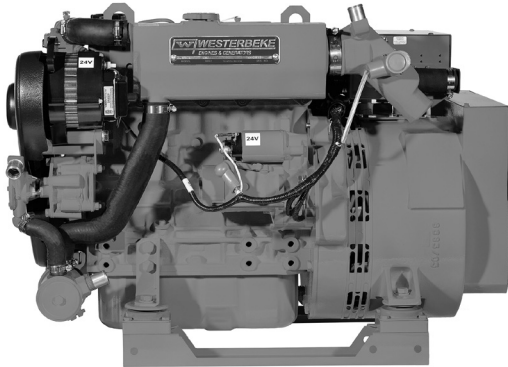

Fully networked to NMEA 2000®



15.0/12.0 EDTA Marine Diesel Generator
(Optional 24V shown.)

The First Electronic Diesel Generators NMEA 2000® Certified

Westerbeke D-NET™ electronic generators are equipped with standard NMEA 2000® compliant databus communication. NMEA 2000® is a network for shipboard communications developed under National Marine Electronics Association (NMEA) standards. NMEA 2000® generators, combined with other certified components, allow boat builders and their customers to significantly reduce the cost, weight and space normally required to run cables throughout the vessel. All certified components freely communicate and are linked to just one NMEA 2000® cable using “T” connections that simplify networking.

Information At Your Fingertips

All Westerbeke D-NET™ generators have available digital controls offering simplified and easy to understand information on operational status and, if necessary, system diagnostics. Westerbeke also features “at a glance” illuminated lights indicating proper operation. They monitor battery voltage, generator voltage, generator frequency, oil pressure, coolant and exhaust temperature. All this information may be viewed from a distance – all green lights indicate referenced systems are functioning properly. Further details are available on the screen display. The user may conveniently scroll for operational or diagnostic information without encountering “codes”. Westerbeke uses text so the user does not have to refer to a manual to decipher numeric information.

Quiet, Slow-Speed Digital Operation

Operating at 1800-rpm with a newly designed, tuned air intake silencer and 3-cylinder engine, the 15.0 EDTA generator runs smooth and quiet. Augmenting this desired effect is the electronic governing that virtually eliminates “droop” when load is applied. Include the optional Sound Guard SST with high quality stainless steel base and frame with stylish powder coated aluminum panels and you have a generator as attractive as it is quiet.

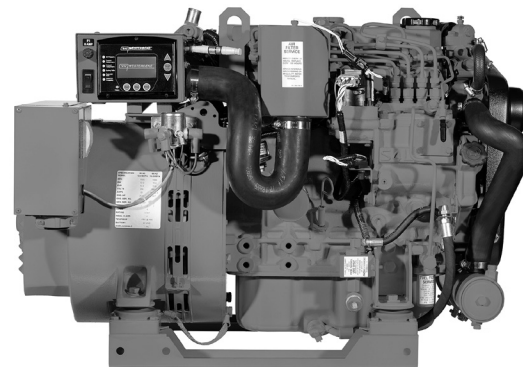

15.0/12.0 EDTA Marine Diesel Generator
(Optional 24V shown.)

Standard Features

- NMEA 2000® compliant databus communication
- Digital display and diagnostics panel
- Electronic governing
- Safety shut-downs: overspeed, underspeed, low oil pressure, high exhaust and high coolant temperature
- AC circuit breaker
- 50 amp battery charging alternator
- Power take-off interface
- Self-bleeding fuel system
- Fresh water cooling and coolant recovery tank
- 45 degree water injected exhaust elbow
- Gear driven raw water pump
- Tuned air intake silencer
- Anti-vibration mounts – fail safe rubber type
- Lube oil drain hose and drip tray
- Oil fill – top and side
- Belt guard
- Operators' Manual and parts list
- 5-year limited warranty
- Meets CARB & U.S. EPA regulations

Digital Display



Generator Design

DESIGN: Brushless, four pole, revolving, power takeoff.
VOLTAGE REGULATION: Standard +/- 5% no load to full load.
FREQUENCY REGULATION: .5 Hz (.6%) no load to full load.
INSULATION: Class "H" as defined by NEMA MG1-1.65.

TEMPERATURE RISE: Within NEMA MG1-22.40 definition when operating at full load.

COOLING: Cast centrifugal blower, direct connected.

ELECTROMAGNETIC INTERFERENCE LEVEL: Exceeds requirements for most marine radio-telephones and standard TVs.

Model	Electrical Characteristics					Ratings		Engine	
	Volts	Amps	Hertz	Phase	Wire	Power Factor	KW	RPM	Start
15.0 EDTA-614	120/240	125/62.5	60	1	4	1.0	15.0	1800	Remote
12.0 EDTA-514	230	52.1	50	1	4	1.0	12.0	1500	Remote

Three phase units are available at these ratings.

Specifications

Number of cylinders	4 Cylinder vertical in-line	
Type	4 cycle	
Displacement	107.27 cu. in. (1.758 liter)	
Bore and stroke	3.07" x 3.62" (78.0 mm x 92.0 mm)	
Compression ratio	22:1	
Rated rpm @ 60/50Hz	1800/1500	
HP @ 1800 rpm	24.6 Standby / 22.7 Prime	
Maximum angle of operation	15 continuous, 30 intermittent	
Exhaust elbow connection	2" OD (50.8mm)	
Raw water connection	1" OD (25.4mm)	
Dry weight	574 lbs. (260.4 kg) approx.	
Combustion system	Swirl type	
Aspiration	Naturally aspirated	
Lubrication system	Forced lubrication by trochoid pump	
Cooling system	8 quarts (7.6 liters)	
Starting aid	12 volt sheathed type glow plug	
Fuel consumption (approx.)	1800 rpm	1500 rpm
100% load GPH (LPH)	1.62 (6.1)	1.28 (4.9)
75% load GPH (LPH)	1.19 (4.5)	0.97 (3.7)
50% load GPH (LPH)	0.87 (3.3)	0.72 (2.7)
25% load GPH (LPH)	0.61 (2.3)	0.54 (2.0)
Fuel injection pump	Bosch type	
Governor	Electronic	
Injectors	Throttle type	
Fuel Filter	Primary and secondary	
Fuel transfer pump	12 volt electric type	

Fuel supply and return piping 1/4" ID (6.35 mm) minimum
3/8" ID (9.53 mm) maximum

Lube oil filter	Full flow, spin-on element
Lubricant capacity	5.5 quarts (5.2 liters)
Electrical system	12 volts DC, negative ground
Starting motor	12 volt, solenoid, actuated shift
Alternator	50 amps (12 volts)
Cranking amps	270 @ 69 degrees F

Construction – Engine Components

Cylinder head	Cast Iron
Cylinder block	Cast Iron
Crankshaft	Forged crankshaft, four main bearings
Valves	Overhead rotating type
Fuel System	Self-bleeding
Intake system	Tuned intake silencer for maximum noise reduction
Cooling system	Fresh water-cooled with shell and tube type heat exchanger
Exhaust manifold	Cast aluminum, fresh water-cooled

Optional Equipment

- Remote digital display and start/stop
- Sound Guard SST
- Hydro-hush muffler and fittings; fuel water separator
- Anti-siphon valve with 1" inch stainless steel loop
- Ship-to-shore switch; power take-off adapter
- "A" on board spare parts kit
- "B" extended cruising spare parts kit
- Generator set available painted white upon request (standard red)

Dimensions

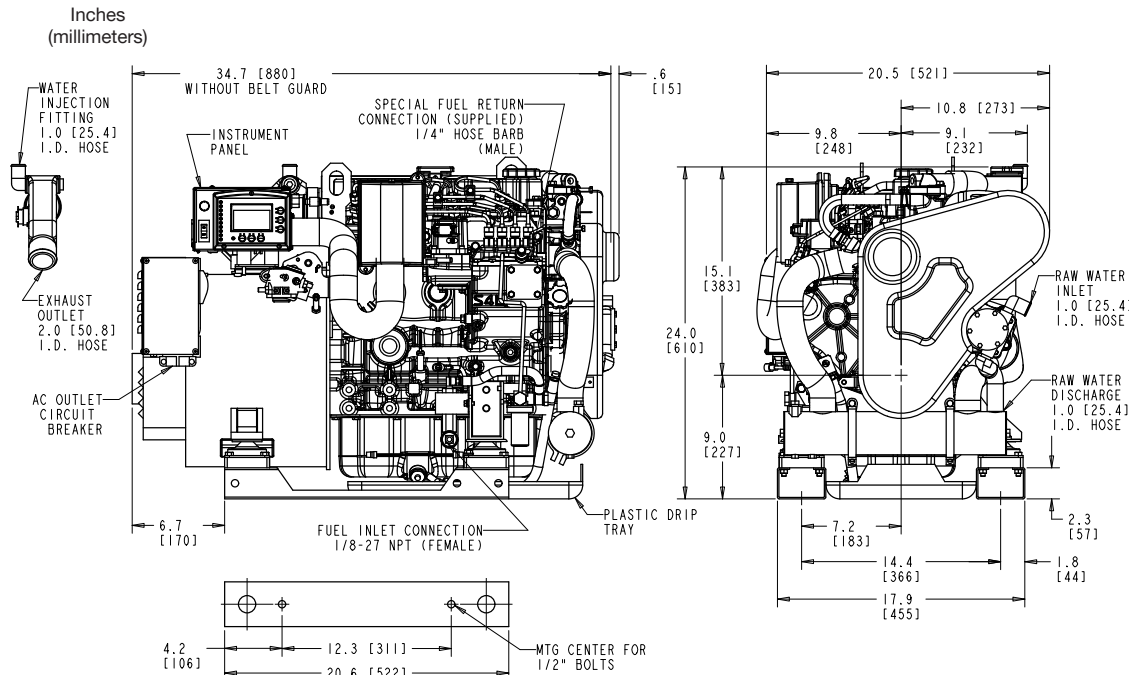

Optional
Sound Guard SST
PN 53463
(for digital product only)

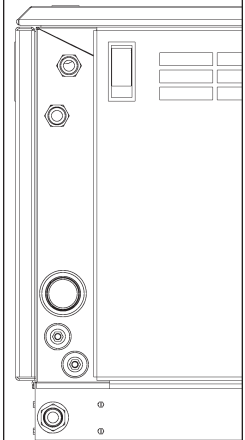

SST
Length: 39.5" (1,003mm)
Width: 23.2" (589mm)
Height: 25.3" (643mm)
Weight: 94 lbs. (43kg)